

Rhodesia - Double Heads - 10d. Printings

Printing	SG/RSC#	Colour	Plate	Frame
1A	149	Bright scarlet & mauve	LG I	I
1B	RSC-A ¹	Scarlet & maroon	LG I	I
2A	150	Deep rose-red & brown purple	LG II	I
-	150 (v.1) [*]	Deep rose-red & 'aniline' brown-purple	LG II	I
2B	RSC-B ²	Deep rose-red & 'aniline' deep dull purple	LG II	I
3A	RSC-C	Scarlet-vermilion & (purplish) maroon	TE I (1)	I
3B	RSC-D1 ³	Carmine-vermilion & (brownish) maroon	TE I (1) ³	I
4A	RSC-D2 ³	Carmine-vermilion & (brownish) maroon	TE I (2A) ³	I
4B	RSC-E	vermilion & maroon	TE I (2A)	I
4C ³	RSC-F ^{**}	Orange-vermilion & deep dull purple	TE I (2A)	I



SG 149 Bright Scarlet & Mauve
 P. 14 Long Gash 1 - Position 2
 "Long Gash in Queen's Ear"

* - Based on the classifications in 1987 Sotheby's / Gibbs Catalogue.

** - Added to the RSC list after the article on the 10d. was published.

Frame States: There is only one frame state for the 10d., with virtually no evidence of maintenance work or re-entry.

¹ - RSC-A has a paler head colour (whiter, i.e., more worn plate) than SG 149 indicating a later LG I printing.

² - In the LG II group (Printings 2A to 2B) the frames go from a non-aniline pale purple to a very deep (& highly aniline) deep purple. At the extreme end is a shade that Simpson (and others) called "Cold Violet." A mere handful of examples are known. This is RSC-B. The vast remainder should be 150 (v.1) above, a rather large range. To qualify as RSC-B a candidate must be mint and in very good condition, and even then it needs to be appreciated that RSC-B may be the result of a moisture phenomenon: over-dampening paper during the printing process. (See also 2/- SG 154a, 3/- RSC-B, and 5/- RSC-B, where a similar process may have played a role.)

³ - Colours are the same (for the most part), but from different states of the plate; in TE I (1) (Printing 3) the portrait definition is somewhat finer and more delicate; in TEII (2) (Printing 4) the portraits are somewhat whiter and marginally more coarse and flaws are more likely to be evident.

⁴ - Printing 4C (RSC-F) is distinct from Printing 4B (RSC-E) and 4A (RSC-D) in that 1) portraits are distinctly more orange; 2) the frame has a nuance of purple or violet; 3) the gum is somewhat cracked.

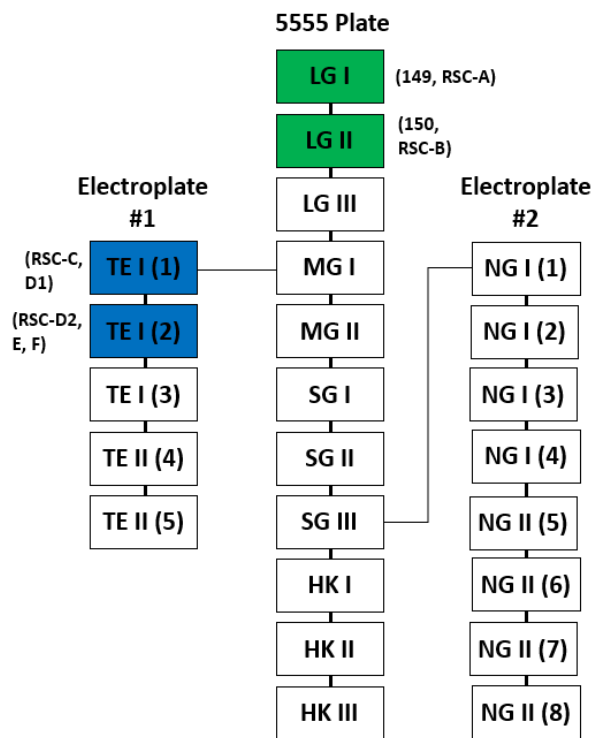



SG 149 Bright Scarlet & Mauve
P. 14 Long Gash I



RSC-A Scarlet & Maroon
P. 14 Long Gash I



SG 150 Deep Rose-Red & Brown Purple
P. 14 Long Gash II



SG 150 v1 Deep Rose-Red & 'Aniline' Brown Purple
P. 14 Long Gash II



RSC-B Dp Rose-Red & 'Aniline' Dp Dull Purple
P. 14 Long Gash II



RSC-C Scarlet-Vermilion & (Purplish) Maroon
P. 14 Thick Ear I (1)



RSC-D1 Carmine-Vermilion & (Brownish) Maroon
P. 14 Thick Ear I (1)



RSC-D2 Carmine-Vermilion & (Brownish) Maroon
P. 14 Thick Ear I (2)



RSC-E Vermilion & Maroon
P. 14 Thick Ear I (2)



RSC-F Orange-Vermilion & Deep Dull Purple
P.14 Thick Ear I (2)